

403035

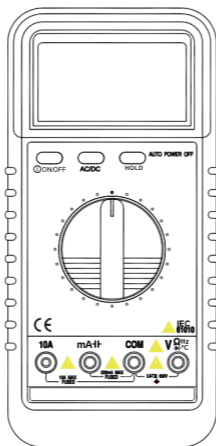

DIGITAL MULTIMETER



USER'S MANUAL

Meridian International Co., Ltd
www.meridianintl.com

CONTENTS

1. SAFETY INFORMATION.....	1
2. DESCRIPTION.....	3
3. OPERATING INSTRUCTION.....	5
3.1 Measuring voltage.....	5
3.2 Measuring current.....	6
3.3 Measuring frequency.....	6
3.4 Measuring resistance.....	7
3.5 Measuring capacitance.....	7
3.6 Testing diode.....	8
3.7 Testing continuity.....	8
3.8 Temperature measurement.....	9
4. SPECIFICATIONS.....	9
5. ACCESSORIES.....	12
6. BATTERY & FUSE REPLACEMENT.....	41

1. SAFETY INFORMATION

This multimeter has been designed according to IEC61010 concerning electronic measuring instruments with an overvoltage category (CAT III 600V) and pollution 2.

Follow all safety and operating instructions to ensure that the meter is used safely and is kept in good operating condition.

1.1 PRELIMINARY

※ When using this meter, the user must observe all normal safety rules concerning:

- Protection against the dangers of electrical current.
- Protection of the meter against misuse.

※ Full compliance with safety standards can be guaranteed only if used with test leads supplied. If necessary, they must be replaced with the same model or same electronic ratings. Measuring leads must be in good condition.

1.2 DURING USE

※ Never exceed the protection limit values indicated in specifications for each range of measurement.

※ When the meter is linked to measurement circuit, do not touch unused terminals.

※ When the value scale to be measured is unknown beforehand, set the range selector at the highest position.

※ Before rotating the range selector to change

functions, disconnect test leads from the circuit under test.

※ When carrying out measurements on TV or switching power circuits, always remember that there may be high amplitude voltages pulses at test points which can damage the meter.

※ Never perform resistance measurements on live circuits.

※ Always be careful when working with voltages above 60V dc or 30V ac rms. Keep fingers behind the probe barriers while measuring.

1.3 SYMBOLS



Important safety information, refer to the operating manual.



Dangerous voltage may be present.



Earth ground



Double insulation (Protection class II)

1.4 MAINTENANCE

※ Before opening the meter, always disconnect test leads from all sources of electric current.

※ For continue protection against fire, replace fuse only with the specified voltage and current ratings:
F1: 250mA/600V F2: 10A/600V

※ If any faults or abnormalities are observed, the meter can not be used any more and it has to be

checked out.

※ Never use the meter unless the back cover is in place and fastened fully.

※ To clean the meter, use a damp cloth and mild detergent only, do not use abrasives or solvents on it.

2. DESCRIPTION

This meter is a portable professional measuring instrument with 3 1/2 digit LCD, capable of performing functions:

- DC and AC voltage measurement
- DC and AC current measurement
- Resistance measurement
- Capacitance measurement
- Diode and transistor test

Some models of this series also provide functions:

- Temperature measurement
- Frequency measurement

NAMES OF COMPONENTS

- 1 Power switch button
- 2 AC/DC select button
- 3 Hold function button
- 4 LCD display
- 5 Rotary switch
- 6 Input jacks

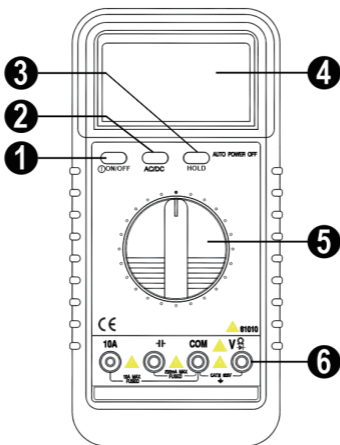

2.1 FUNCTION AND RANGE SELECTOR

There are 10 functions and 33 ranges provided. A rotary switch is used to select functions as well as ranges.

2.2 POWER SWITCH

A push - push switch is used to turn the meter on or off. To extend the battery life, Auto Power - Off function is provided (Optional). The meter will be turned off automatically within around 30 minutes. To turn on the meter again, Push the power switch to release it and then push it once more.

2.3 INPUT JACKS

This meter has four input jacks that are protected against overload to the limits. During use, connect the black test lead to the COM jack and red test lead as shown below:

Function	Red lead connection	Input limits
200mV	V/ Ω /Hz	250Vdc or rms ac
V \sim /V \sim	V/ Ω /Hz	600Vdc or rms ac (sine)
Ω /Hz/ \bullet) I \rightarrow I $^\circ$ C	V/ Ω /Hz	250Vdc or rms ac
H	μ A/mA	250Vdc or rms ac
μ mA \sim /~	μ A/mA	200mA dc or rms continuous
10A \sim /~	A	10A for 15 seconds maximum each 10min

3. OPERATING INSTRUCTION

3.1 MEASURING VOLTAGE

1. Connect the black test lead to the COM jack and the red test lead to the V/ Ω /Hz jack.
2. Set the rotary switch at the desired V range position and connect test leads across the source or load under measurement.(If you want to measure AC source, please press the AC/DC select button, until the AC symbol show on LCD; If you want to measure DC source, please press the AC/DC select button, until the AC symbol disappear on LCD.)
3. Read LCD display.
4. When only the figure“1” is displayed, it indicates

overrange situation and the higher range has to be selected.

3.2 MEASURING CURRENT

1. Connect the black test lead to the COM jack and the red test lead to the A jack for a maximum of 200mA. For a maximum of 10A, move the red lead to the A jack.
2. Set the rotary switch at desired A range position and connect test leads in series with the load under measurement. (If you want to measure AC source, please press the AC/DC select button, until the AC symbol show on LCD; If you want to measure DC source, please press the AC/DC select button, until the AC symbol disappear on LCD.)
3. Read LCD display.
4. When only the figure “1” displayed, it indicates overrange situation and the higher range has to be selected.

3.3 MEASURING FREQUENCY

1. Connect the black test leads to the COM jack and the red test lead to the V/ Ω /Hz jack.
2. Set the rotary switch at KHz position and connect test leads across the source or load under measurement.

NOTE:

1. Reading is possible at input voltages above 10Vrms, but the accuracy is not guaranteed.
2. In noisy environment, it is preferable to use shield

cable for measuring small signal.

3.4 MEASURING RESISTANCE

1. Connect the black test lead to the COM jack and the red test lead to the V/ Ω /Hz jack. (NOTE :The polarity of red lead connection is positive“ + ”)
2. Set the rotary switch at desired Ω range position and connect test leads across the resistance under measurement. Read LCD display.

NOTE:

1. For resistance above $1M\Omega$, the meter may take a few seconds to stabilize reading.
2. When the input is not connected, i.e. at open circuit, the figure “1” will be displayed for the overrange condition.
3. When checking in - circuit resistance, be sure the circuit under test has all power removed and all capacitors are full discharged.
4. At $200M\Omega$ range display is 10 counts when test leads are shorted. These counts have to be subtracted from measuring results. For example, when measuring $100M\Omega$ resistance, the reading will be 101.0 and the correct measuring result should be $101.0 - 1.0 = 100.0 M\Omega$.

3.5 MEASURING CAPACITANCE

1. Set the rotary switch at desired F range position.
2. Before measure capacitor, be sure that the capacitor has been discharged fully.

3. Connect the red test lead to the mA terminal, the black test lead to the COM terminal.

3.6 TESTING DIODE

1. Connect the black test lead to the COM jack and the red test lead to the V/ Ω jack. (NOTE: The polarity of red lead connection is positive “ + ”) 2. Set the rotary switch at \blacktriangleright position and connect the red lead to the anode, the black lead to the cathode of the diode under testing. The meter will show the approx. Forward voltage drop of the diode. If the lead connection is reversed, only figure “ 1 ” will be displayed.

3.7 CONTINUITY TEST

1. Connect the black test lead to the COM jack and the red test lead to the V/ Ω jack.
2. Set the rotary switch at \mathcal{N} position and connect test leads across two points of the circuit under testing. If continuity exists (i.e. resistance less than about 70 Ω), built —in buzzer will sound.

3.8 MEASURING TEMPERATURE

1. Set the rotary switch at TEMP position and the LCD display will show the ambient temperature.
2. Insert “K” type thermocouple probe to the V terminal and COM terminal. Read LCD display.

4. SPECIFICATIONS

Accuracy is specified for a period of one year after calibration and at 18°C to 28°C (64°F to 82°F) with relative humidity to 80%.

Accuracy specifications are given as:

± % of reading ± number of least significant digits.

4.1 GENERAL

MAXIMUM VOLTAGE BETWEEN TERMINALS AND EARTH GROUND:

600V DC or 600 rms AC (sine)

FUSE PROTECTION:

mA: F 250mA/600V 10A: F 10A/600V

POWER SUPPLY: 9V battery, NEDA 1604 or 6F22

DISPLAY: LCD, 1999 counts MAX, updates 2-3/sec

MEASURING METHOD: Dual - slope integration A/D converter

OVERRANGE INDICATION:

“1” figure only on the display

POLARITY INDICATION:

“—” displayed for negative polarity

LOW BATTERY INDICATION: “ ” displayed

OPERATING TEMPERATURE:

0°C to 40°C (32°F to 104°F)

STORAGE TEMPERATURE:

-10°C to 50°C (14°F to 122°F)

DIMENSION: 91×189×31.5mm

WEIGHT: 310g (including battery)

4.2 AC VOLTAGE

Range	Resolution	Accuracy
200mV	0.1mV	$\pm 1.2 \% \text{ of rdg} \pm 3 \text{ digit}$
2V	1mV	$\pm 0.8 \% \text{ of rdg} \pm 3 \text{ digit}$
20V	10mV	$\pm 0.8 \% \text{ of rdg} \pm 3 \text{ digit}$
200V	100mV	$\pm 0.8 \% \text{ of rdg} \pm 3 \text{ digit}$
600V	1V	$\pm 1.2 \% \text{ of rdg} \pm 2 \text{ digits}$

.Input impedance: 10M Ω

Frequency range: 40Hz to 400Hz

Response: average, calibrated in rms of sine wave

4.3 DC VOLTAGE

Range	Resolution	Accuracy
200mV	0.1mV	$\pm 0.5 \% \text{ of rdg} \pm 1 \text{ digit}$
2V	1mV	$\pm 0.5 \% \text{ of rdg} \pm 1 \text{ digit}$
20V	10mV	$\pm 0.5 \% \text{ of rdg} \pm 1 \text{ digit}$
200V	100mV	$\pm 0.5 \% \text{ of rdg} \pm 1 \text{ digit}$
600V	1V	$\pm 0.8 \% \text{ of rdg} \pm 2 \text{ digits}$

Input Impedance: 10M Ω

4.4 AC CURRENT

Range	Resolution	Accuracy
200 μ A	0.1 μ A	$\pm 1.0 \% \pm 3$
2mA	1 μ A	$\pm 1.0 \% \pm 3$
20mA	10 μ A	$\pm 1.0 \% \pm 3$
200mA	100 μ A	$\pm 1.8 \% \pm 3$
10A	10mA	$\pm 3.0 \% \pm 7$

Frequency Range: 40Hz to 400Hz

Response: Average, calibrated in rms of sine wave

4.5 DC CURRENT

Range	Resolution	Accuracy
200 μ A	0.1 μ A	$\pm 0.8 \% \pm 1$
2mA	1 μ A	$\pm 0.8 \% \pm 1$
20mA	10 μ A	$\pm 0.8 \% \pm 1$
200mA	100 μ A	$\pm 1.5 \% \pm 5$
10A	10mA	$\pm 2.0 \% \pm 5$

4.6 CAPACITANCE

Range	Resolution	Accuracy
2nF	1pF	$\pm 4.0\% \pm 20$
20nF	10pF	
200nF	100pF	
20 μ F	10nF	
200 μ F	100nF	

4.7 FREQUENCY

Range	Resolution	Accuracy
2KHz	1Hz	$\pm 2.0 \% \pm 10$
20kHz	10Hz	$\pm 1.5 \% \pm 10$

Sensitivity: 200mV rms and input no more 10V rms.

4.8 RESISTANCE

Range	Resolution	Accuracy
200 Ω	0.01 Ω	$\pm 0.8 \% \pm 3$

2K Ω	0.1 Ω	$\pm 0.8 \% \pm 1$
20K Ω	1 Ω	$\pm 0.8 \% \pm 1$
200K Ω	10 Ω	$\pm 0.8 \% \pm 1$
2M Ω	100 Ω	$\pm 0.8 \% \pm 1$
20M Ω	1K Ω	$\pm 1.8 \% \pm 2$
200M Ω	10K Ω	$\pm 5.0 \%$ of (rdg-10digits) ± 10

Note: On 200M Ω range, if short input, display will read 1M Ω , this 1M Ω should be subtracted from measurement results.

4.9 TEMPERATURE

Range	Resolution	Accuracy
-20 $^{\circ}\text{C}$ ~ 0 $^{\circ}\text{C}$	1 $^{\circ}\text{C}$	$\pm 5.0 \% \pm 4$
0 $^{\circ}\text{C}$ ~ 400 $^{\circ}\text{C}$		$\pm 1.0 \% \pm 3$
400 $^{\circ}\text{C}$ ~ 1000 $^{\circ}\text{C}$		$\pm 2.0 \%$

5. ACCESSORIES

5.1 SUPPLIED WITH THE MULTIMETER

Test leads	Electric Rating 1000V, 10A	1 couple
Battery	9V NEDA 1604 or 6F22	1 pcs
Operating Manual		1 pcs
Holster		1 pcs

OPTIONAL ACCESSORY: "k" thermocouple

5.2 HOW TO USE THE HOLSTER

The holster is used to protect the meter and to make the

measurement more comfortable, it comes with tow stands installed together. The figure shows how to use the holster to:

A: Support the meter with a standard angle.

B: Support the meter with a small angle using the little stand

C: Hang the meter on the wall using the little stand.

Take the little stand off from the back side of the large and insert it into holes located upper on the holster.

D. hold test leads

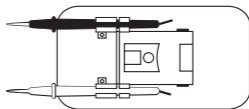
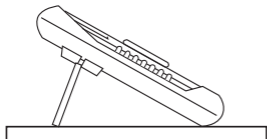
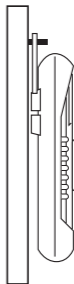
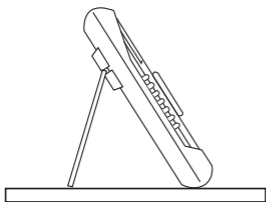

6. BATTERY & FUSE REPLACEMENT

If the sign “  ” appears on the LCD display, it indicates that battery should be replaced.

Remove screws on the back cover and open the case. Replace the exhausted battery with a new one.

Fuse rarely need replacement and blow almost always as a result of the operator's error. Open the case as mentioned above, and then take the PCB out from the front cover. Replace the new fuse with same ratings.



WARNING

Before attempting to open the case, be sure that test leads have been disconnected from measurement circuits to avoid electric shock hazard.

For protection against fire, replace fuse only with specified ratings:

F1: 250mA/600V (quick acting)

F2: 10A/600V (quick acting)



403035 - DIGITAL MULTIMETER

CONTENTS

1. SAFETY INFORMATION.....	1
2. DESCRIPTION.....	3
3. OPERATING INSTRUCTION.....	5
4. SPECIFICATIONS.....	9
5. ACCESSORIES.....	12
6. BATTERY & FUSE REPLACEMENT.....	14

Meridian International Co., Ltd
www.meridianintl.com

1. SAFETY INFORMATION

This multimeter has been designed according to IEC 1010 concerning electronic measuring instruments with an overvoltage category (CAT II) and pollution 2.

Follow all safety and operating instructions to ensure that the meter is used safely and is kept in good operating condition.

1.1 PRELIMINARY

※ When using this meter, the user must observe all normal safety rules concerning:

- Protection against the dangers of electrical current.
- Protection of the meter against misuse.

※ Full compliance with safety standards can be guaranteed only if used with test leads supplied. If necessary, they must be replaced with the same model or same electronic ratings. Measuring leads must be in good condition.

1.2 DURING USE

※ Never exceed the protection limit values indicated in specifications for each range of measurement.

※ When the meter is linked to measurement circuit, do not touch unused terminals.

※ When the value scale to be measured is unknown beforehand, set the range selector at the highest position.

※ Before rotating the range selector to change functions, disconnect test leads from the circuit under

test.

※ When carrying out measurements on TV or switching power circuits, always remember that there may be high amplitude voltages pulses at test points which can damage the meter.

※ Never perform resistance measurements on live circuits.

※ Always be careful when working with voltages above 60V dc or 30V ac rms. Keep fingers behind the probe barriers while measuring.

1.3 SYMBOLS



Important safety information, refer to the operating manual.



Dangerous voltage may be present.



Earth ground



Double insulation (Protection class II)

1.4 MAINTENANCE

※ Before opening the meter, always disconnect test leads from all sources of electric current.

※ For continue protection against fire, replace fuse only with the specified voltage and current ratings:
F1: 2A/250V F2: 10A/250V

※ If any faults or abnormalities are observed, the meter can not be used any more and it has to be checked out.

- ※ Never use the meter unless the back cover is in place and fastened fully.
- ※ To clean the meter, use a damp cloth and mild detergent only, do not use abrasives or solvents on it.

2. DESCRIPTION

This meter is a portable professional measuring instrument with 3 1/2 digit LCD, capable of performing functions:

- DC and AC voltage measurement
- DC and AC current measurement
- Resistance measurement
- Capacitance measurement
- Diode and transistor test

Some models of this series also provide functions:

- Temperature measurement
- Frequency measurement

NAMES OF COMPONENTS

- 1 Power switch
- 2 Capacitor measurement socket
- 3 Temperature measurement socket
- 4 LCD display
- 5 Transistor test socket
- 6 Rotary switch
- 7 Input jacks

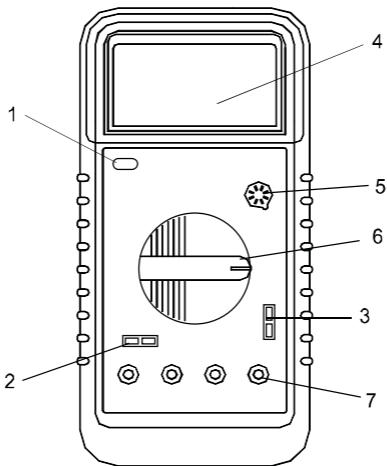

2.1 FUNCTION AND RANGE SELECTOR



There are 9 functions and 32 ranges provided. A rotary switch is used to select functions as well as ranges.

2.2 POWER SWITCH

A push - push switch is used to turn the meter on or off. To extend the battery life, Auto Power - Off function is provided (Optional). The meter will be turned off automatically within around 40 minutes. To turn on the meter again, Push the power switch to release it and then push it once more.

2.3 INPUT JACKS

This meter has four input jacks that are protected against overload to the limits. During use, connect the black test lead to the COM jack and red test lead as shown below:

Function	Red lead connection	Input limits
200mV $\overline{\square}$ /200mV	V/ Ω /Hz	250Vdc or rms ac
V $\overline{\square}$ /V~	V/ Ω /Hz	1000Vdc, 700V rms ac (sine)
Ω	V/ Ω /Hz	250Vdc or rms ac
Hz	V/ Ω /Hz	250Vdc or rms ac
 	V/ Ω /Hz	250Vdc or rms ac
A $\overline{\square}$ /A~	mA	10A dc or rms as continuous
10A $\overline{\square}$ /10A~	A	20A for 15 seconds maximum

3. OPERATING INSTRUCTION

3.1 MEASURING VOLTAGE

1. Connect the black test lead to the COM jack and the red test lead to the V/ Ω /Hz jack.
2. Set the rotary switch at the desired V $\overline{\square}$ or V~ range position and connect test leads across the source or load under measurement.
3. Read LCD display. The polarity of the red connection will be indicated when making a dc voltage measurement.
4. When only the figure "1" is displayed, it indicates

overrange situation and the higher range has to be selected.

3.2 MEASURING CURRENT

1. Connect the black test lead to the COM jack and the red test lead to the A jack for a maximum of 200mA. For a maximum of 20A, move the red lead to the A jack.
2. Set the rotary switch at desired A_{DC} or A_{AC} range position and connect test leads in series with the load under measurement.
3. Read LCD display. The polarity of the red lead connection will be indicated when making a DC measurement.
4. When only the figure "1" displayed, it indicates overrange situation and the higher range has to be selected.

3.3 MEASURING FREQUENCY

1. Connect the black test leads to the COM jack and the red test lead to the V/ Ω /Hz jack.
2. Set the rotary switch at KHz position and connect test leads across the source or load under measurement.

NOTE:

1. Reading is possible at input voltages above 10Vrms, but the accuracy is not guaranteed.
2. In noisy environment, it is preferable to use shield cable for measuring small signal.

3.4 MEASURING RESISTANCE

1. Connect the black test lead to the COM jack and the red test lead to the V/ Ω /Hz jack. (NOTE :The polarity of red lead connection is positive“+”)
2. Set the rotary switch at desired Ω range position and connect test leads across the resistance under measurement. Read LCD display.

NOTE:

1. For resistance above $1\text{M}\Omega$, the meter may take a few seconds to stabilize reading.
2. When the input is not connected, i.e. at open circuit, the figure “1” will be displayed for the overrange condition.
3. When checking in - circuit resistance, be sure the circuit under test has all power removed and all capacitors are full discharged.
4. At $200\text{M}\Omega$ range display is 10 counts when test leads are shorted. These counts have to be subtracted from measuring results. For example, when measuring $100\text{M}\Omega$ resistance, the reading will be 101.0 and the correct measuring result should be $101.0 - 1.0 = 100.0\text{M}\Omega$.

3.5 MEASURING CAPACITANCE

1. Set the rotary switch at desired F position.
2. Before inserting capacitor under measurement into capacitance testing socket, be sure that the capacitor has been discharged fully.
3. When measuring capacitors with shorter leads, a

testing adapter is provided with the meter. Insert the adapter into the capacitance testing socket on the front panel to continue measurements.

WARNING!

To avoid shock, be sure the capacitor measuring adapter has been removed before changing to another function measurement.

3.6 TESTING DIODE

1. Connect the black test lead to the COM jack and the red test lead to the V/Ω jack. (NOTE: The polarity of red lead connection is positive “ Ω ”) 2. Set the rotary switch at  position and connect the red lead to the anode, the black lead to the cathode of the diode under testing. The meter will show the approx. Forward voltage drop of the diode. If the lead connection is reversed, only figure “ 1 ” will be displayed.

3.7 TESTING TRANSISTOR

1. Set the rotary switch at hFE position.
2. Identify whether the transistor is NPN or PNP type and locate Emitter, Base and Collector lead. Insert leads of the transistor to be tested into proper holes of the testing socket on the front panel.
3. LCD display will show the approximate hFE value at the test condition of base current 10μA and Vce 3.2V.

3.8 CONTINUITY TEST

1. Connect the black test lead to the COM jack and the

red test lead to the V \square jack.

2. Set the rotary switch at N position and connect test leads across two points of the circuit under testing. If continuity exists (i.e. resistance less than about 70 \square), built – in buzzer will sound.

3.9 MEASURING TEMPERATURE

1. Set the rotary switch at TEMP position and the LCD display will show the ambient temperature.

2. Insert “K” type thermocouple into the temperature measuring socket on the front panel and contact the object to be measured with the thermocouple probe.

Read LCD display.

WARNING!

To avoid electric shock, be sure the thermocouple has been removed before changing to another function measurement.

4. SPECIFICATIONS

Accuracy is specified for a period of one year after calibration and at 18°C to 28°C (64°F to 82°F) with relative humidity to 80%.

Accuracy specifications are given as:

\square % of reading \square number of least significant digits.

4.1 GENERAL

MAXIMUM VOLTAGE BETWEEN TERMINALS AND EARTH GROUND:

1000V DC or 700 rms AC (sine)

FUSE PROTECTION: mA: F 200mA/250V (A: unfused)
 POWER SUPPLY: 9V battery, NEDA 1604 or 6F22
 DISPLAY: LCD, 19999 counts MAX, updates 2-3/sec
 MEASURING METHOD: Dual - slope integration A/D converter
 OVERRANGE INDICATION:
 "1" figure only on the display
 POLARITY INDICATION:
 "-" displayed for negative polarity
 LOW BATTERY INDICATION: "  " displayed
 OPERATING TEMPERATURE:
 0°C to 40°C (32°F to 104°F)
 STORAGE TEMPERATURE:
 -10°C to 50°C (14°F to 122°F)
 DIMENSION: 91×189×31.5mm
 WEIGHT: 310g (including battery)

4.2 AC VOLTAGE

Range	Resolution	Accuracy
200mV	0.1mV	□ 1.2 □ of rdg □ 3 digit
2V	1mV	□ 0.8 □ of rdg □ 3 digit
20V	10mV	□ 0.8 □ of rdg □ 3 digit
200V	100mV	□ 0.8 □ of rdg □ 3 digit
1000V	1V	□ 1.2 □ of rdg □ 2 digits

.Input impedance: 10MΩ

Frequency range: 40Hz to 400Hz

Response: average, calibrated in rms of sine wave

4.3 DC VOLTAGE

Range	Resolution	Accuracy
200mV	0.1mV	$\pm 0.5\%$ of rdg ± 1 digit
2V	1mV	$\pm 0.5\%$ of rdg ± 1 digit
20V	10mV	$\pm 0.5\%$ of rdg ± 1 digit
200V	100mV	$\pm 0.5\%$ of rdg ± 1 digit
1000V	1V	$\pm 0.8\%$ of rdg ± 2 digits

Input Impedance: $10M\Omega$

4.4 AC CURRENT

Range	Resolution	Accuracy	Burden voltage
2mA	$1\mu A$	$\pm 1.0\%$ ± 3	110mV/mA
20mA	$10\mu A$	$\pm 1.0\%$ ± 3	15mV/mA
200mA	$100\mu A$	$\pm 1.8\%$ ± 3	5.0mV/mA
10A	10mA	$\pm 3.0\%$ ± 7	0.03V/A

Frequency Range: 40Hz to 400Hz

Response: Average, calibrated in rms of sine wave

4.5 DC CURRENT

Range	Resolution	Accuracy	Burden voltage
2mA	$1\mu A$	$\pm 0.8\%$ ± 1	110mV/mA
20mA	$10\mu A$	$\pm 0.8\%$ ± 1	15mV/mA
200mA	$100\mu A$	$\pm 1.5\%$ ± 5	5.0mV/mA
10A	10mA	$\pm 2.0\%$ ± 5	0.03V/A

4.6 CAPACITANCE

Range	Resolution	Accuracy
2000pF	1pF	□ 4.0 □ □ 3
20nF	10pF	
200nF	100pF	
2□F	1nF	
20□F	10nF	

4.7 FREQUENCY

Range	Resolution	Accuracy
2KHz	1Hz	□ 2.0 □ □ 5
20kHz	10Hz	□ 1.5 □ □ 5

Sensitivity: 200mV rms and input no more 10V rms.

4.8 RESISTANCE

Range	Resolution	Accuracy
200Ω	0.01Ω	□ 0.8 □ □ 3
2KΩ	0.1Ω	□ 0.8 □ □ 1
20KΩ	1Ω	□ 0.8 □ □ 1
200KΩ	10Ω	□ 0.8 □ □ 1
2MΩ	100Ω	□ 0.8 □ □ 1
20MΩ	1KΩ	□ 1.8 □ □ 2
200MΩ	10KΩ	□ 5.0 □ of (rdg-10digits) □ 10

Note: On 200M□ range, if short input, display will read 1M□, this 1M□ should be subtracted from measurement results.

4.9 TEMPERATURE

Range	Resolution	Accuracy
-20°C ~ 0°C	1°C	□ 5.0 □ □ 4
0°C ~ 400°C		□ 1.0 □ □ 3
400°C ~ 1000°C		□ 2.0 □

5. ACCESSORIES

5.1 SUPPLIED WITH THE MULTIMETER

Test leads	Electric Rating 1500V, 10A	1 couple
Battery	9V NEDA 1604 or 6F22	1 pcs
Operating Manual		1 pcs
Holster		1 pcs
Capacitance Testing Adapter		1 pcs

OPTIONAL ACCESSORY: “k” thermocouple

5.2 HOW TO USE THE HOLSTER

The holster is used to protect the meter and to make the measurement more comfortable, it comes with two stands installed together. The figure shows how to use the holster to:

- A: Support the meter with a standard angle.
 - B: Support the meter with a small angle using the little stand
 - C: Hang the meter on the wall using the little stand.
- Take the little stand off from the back side of the large and insert it into holes located upper on the holster.
- D. hold test leads

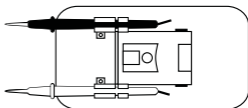
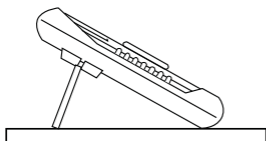
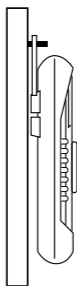
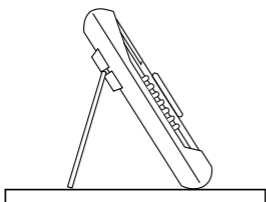

6. BATTERY & FUSE REPLACEMENT

If the sign “  ” appears on the LCD display, it indicates that battery should be replaced.

Remove screws on the back cover and open the case. Replace the exhausted battery with a new one.

Fuse rarely need replacement and blow almost always as a result of the operator's error. Open the case as mentioned above, and then take the PCB out from the front cover. Replace the blown fuse with same ratings.



WARNING

Before attempting to open the case, be sure that test leads have been disconnected from measurement circuits to avoid electric shock hazard.

For protection against fire, replace fuse only with specified ratings:

F1: 200mA/250V (quick acting)